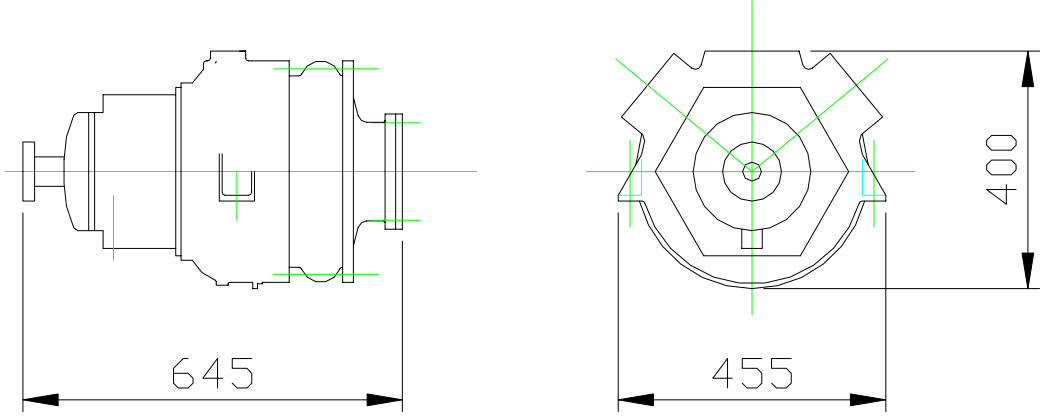
 CARROZZERIA CHINETTI s.r.l ITALY	OBJET		SUBJECT	
	POMPE INCENDIE		FIRE FIGHTING PUMP	
	MODELE		MODEL	
	2T 2012			
	DOC.	PI - 007	DATE	12-01-07

MODELE /MODEL	CHINETTI 2T – 2012
	
CARATTERISTICHE TECNICHE	SPECIFICATIONS
Pompa centrifuga, a due stadi, con diffusore a palette Portata nominale: 2000 lt/min @ 12 bar Max vel. di rotazione: 4'000 rpm Tenuta d'albero : Meccanica Albero con flangia di trascinamento Adescamento automatico con pompa elettrica a palette, 12 ou24 V (Optional) Pre-miscelatore schiuma – 3% et 6% (Optional) Colore : rosso RAL 3000	Centrifugal type, double stage, blade type diffusers Nominal output: 2000 lt/min @ 12 bar Max speed : 4'000 rpm Mechanical shaft seal Shaft head with flange Automatic priming with rotary vanes vacuum pump, electric drive 12 or 24 V DC (Optional) Foam mixer “around the pump” – 3% and 6% (Optional) Painting: red RAL 3000
DIMENSIONS et POIDS	DIMENSIONS & WEIGHT
mm mm 645 x 455 x 400 h Peso a vuoto, in bronzo 160 kg Capacità carter olio : 10 kg Diametro flangia di aspirazione : Ø 100mm Mandate : 2 x 75 mm	mm mm 645 x 455 x 400 height Dry weight, bronze 160 kg Oil pan capacity 10 kg Suction Ø 100 mm Outlets 2 x Ø 75 mm
MATERIALI	MATERIALS
Corpo & giranti: bronzo Albero : acciaio inox superduplex	Body & impellers: bronze Shaft: superduplex stainless steel

Componente	POMPE INCENDIE VEHICULAIRE	Date	Sheet
Item	TRUCK-MOUNTED FIRE-FIGHTING PUMP	08/01/08	1 of 1