 CARROZZERIA CHINETTI s.r.l ITALY	OBJET		SUBJECT	
	POMPE INCENDIE POUR VEHICULES		VEHICULAR FIRE FIGHTING PUMP	
	2T 5012			
	DOC.	PI - 001	DATE	15.03.2003

MODELE /MODEL	2T - 5012
	
SPECIFICATIONS	SPECIFICATIONS
Type centrifuge à deux étages, roues montées en contre face pour l'équilibrage axiale , diffuseurs à ailes Débit nominale: 240 m ³ /hr @ 12 bar Vitesse de rotation maxi: 2500 tours/1' Etanchéité d'arbre mécanique Tête d'axe avec clavette ou bride Amorçage automatique avec pompe à vide à palettes, entraînement électrique à 24 V CC Pré mélangeur émulsifiant @ 3% et 6% Peinture : rouge RAL 3000	Centrifugal type, double stage, counter facing impellers for axial thrust balancing, blade type diffusers Nominal output: 240 m ³ /hr @ 12 bar Max speed : 2500 rpm Mechanical shaft seal Shaft head with key or flange Automatic priming with rotary vanes vacuum pump, electric drive 24 V DC Foam mixer "around the pump" @ 3% and 6% Painting: red RAL 3000
DIMENSIONS et POIDS	DIMENSIONS & WEIGHT
mm 702 x 502 x 485 hauteur Poids à vide, en bronze 250 kg Poids à vide, en alliage léger 150 kg Capacité d'huile 12 kg Aspiration Ø 150 mm Refoulement 2 x Ø 125 mm	mm 657 x 484 x 720 height Dry weight, bronze 250 kg Dry weight, aluminum alloy 150 kg Oil pan capacity 12 kg Suction Ø 150 mm Outlets 2 x Ø 125 mm
MATERIAUX	MATERIALS
Corps & roues: bronze Axe : acier inox	Body & impellers: bronze Shaft: stainless steel

Composante	POMPE INCENDIE VEHICULAIRE	Date	Sheet
Item	VEHICULAR FIRE-FIGHTING PUMP	10/11/08	1 of 1

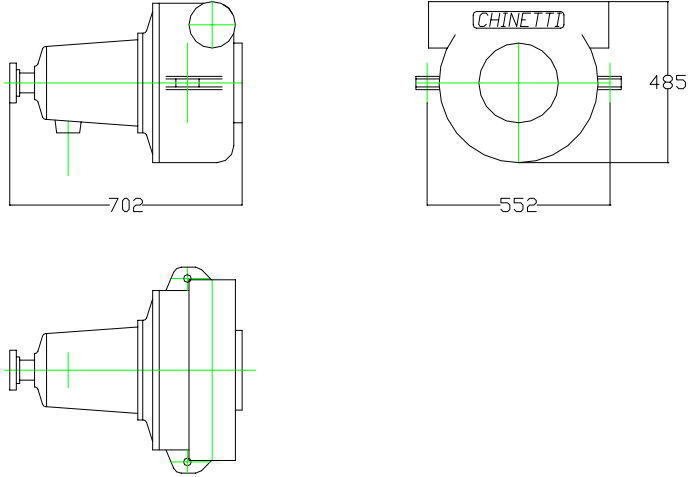

CARROZZERIA
CHINETTI s.r.l
 ITALY

OBJET		SUBJECT	
POMPE INCENDIE POUR VEHICULES		VEHICULAR FIRE FIGHTING PUMP	
2T 5012			
DOC.	PI - 001	DATE	15.03.2003

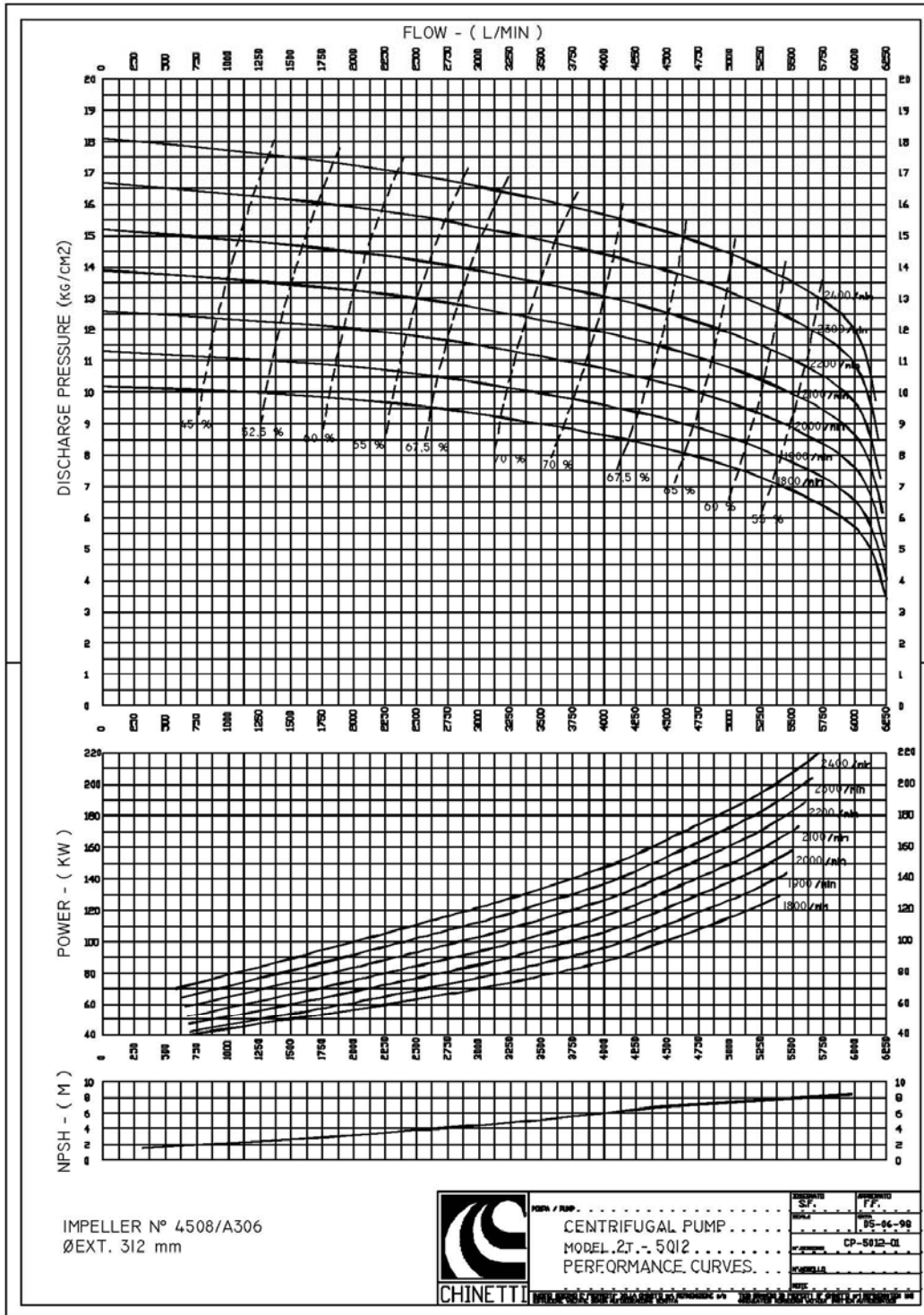

Composante	POMPE INCENDIE VEHICULAIRE	Date	Sheet
Item	VEHICULAR FIRE-FIGHTING PUMP	10/11/08	1 of 1